

Niblite

584

This Class B FF for Cat. III has done it all

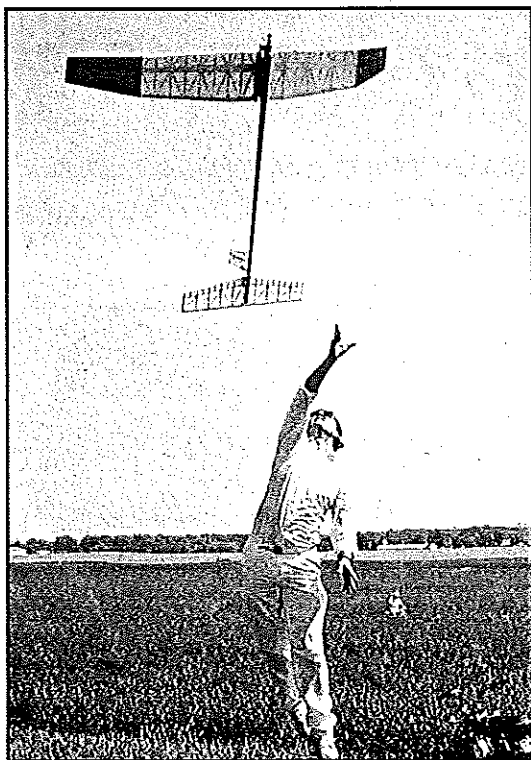

The author and his record-setting model. Niblite has won at every level of competition.

■ Norman D. Poti

Editor's Note: As this issue was being assembled, Niblite 584 won Class B Gas at the 1995 USOC/AMA FF Nats. Congratulations to Norm Poti for another outstanding achievement.

Niblite 584 was developed as a competitive free flight gas model intended primarily for Category III competition. The model reflects a combination of features from my Niblet FIC series and the famous Satellite designs. It represents a state-of-the-art model intended for the experienced builder/flier, and has demonstrated its potential by winning numerous awards.

At the 1993 United States Outdoor Championships this model captured the

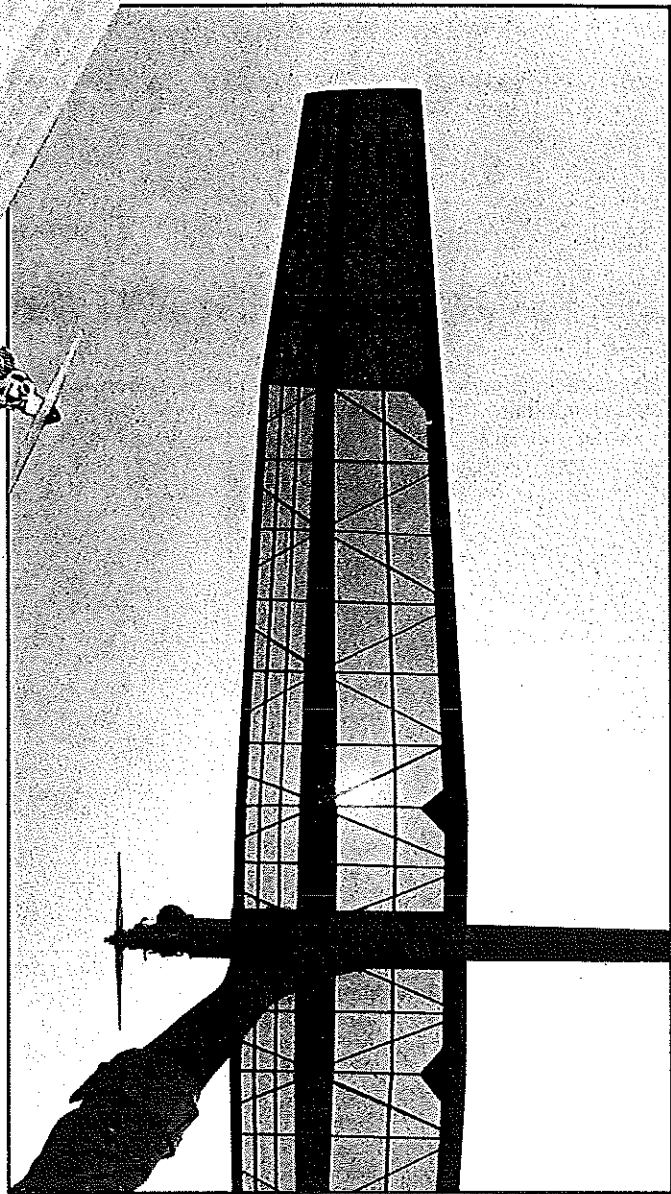
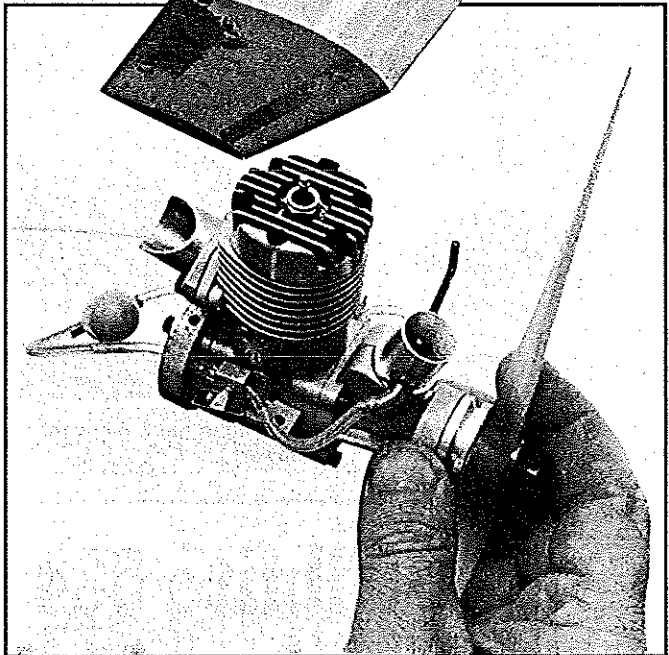
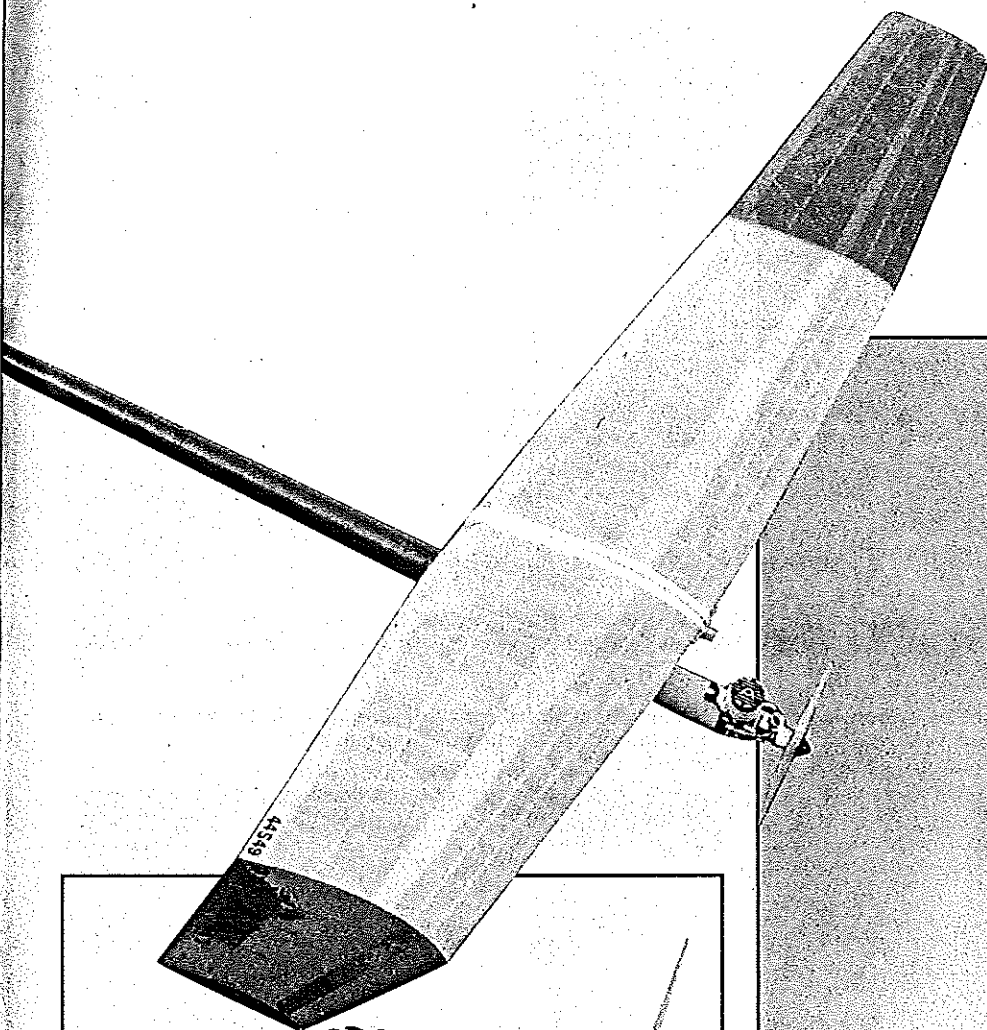

Removable front end allows access to pacifier tank. O.S. Max .25 DF turns an 8 x 3 Poti's Hangar fiberglass prop.

Niblite wing uses geodetic structure with box-type main spar. All ribs are cut from master Simplex airfoil template.

Category III national record, completing 33 maxes for a total of 80 minutes. That accomplishment represents a pinnacle in my 29-year Free-Flight career, and resulted in Niblite's selection as a National Free Flight Society (NFFS) Model Of The Year.

The objective was to build a lightweight 600-square-inch model that could handle the powerful O.S. Max .25 ducted fan engine. The long tail moments and ample dihedral lead to a very stable and consistent model that is

flown with auto rudder and stab, but without bunt. At 752 grams (26.5 ounces) Niblite accelerates quickly under power—a quality essential for four-second Category III flyoff flights—and provides a very buoyant glide.

Niblite weighs the same as an F1C, but has 100 more square inches in the wing, 80% more displacement, and is flown on 60% nitro!

The 584 was first flown in 1990. The original wing was built with an open main spar, no vertical webs, and was covered with

Micafilm. That wing weighed 188 grams and was flown for one contest season, but proved to be too flexible; it could handle bending loads, but was too weak in torsion. The wing would wash out and provide a bunt-like pattern on long engine runs with the stab in a fixed position.

While this aeroelastically induced bunt concept was intriguing, consistency could not be achieved. The wing was stripped, vertical spar webs were added, and the wing was re-covered with MonoKote. The rebuilt wing

Photography by Jim Haught Graphic Design by Bill Thornbro

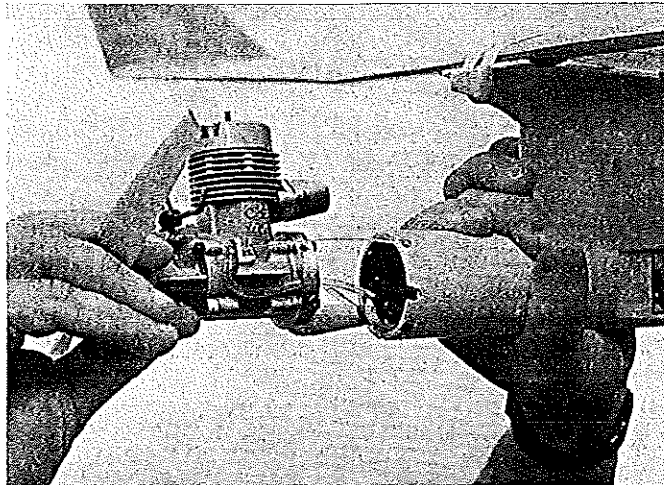

Backplate-style engine mount bolts to front of carbon fuselage tube. Floodoff line from timer to L-shaped bracket.

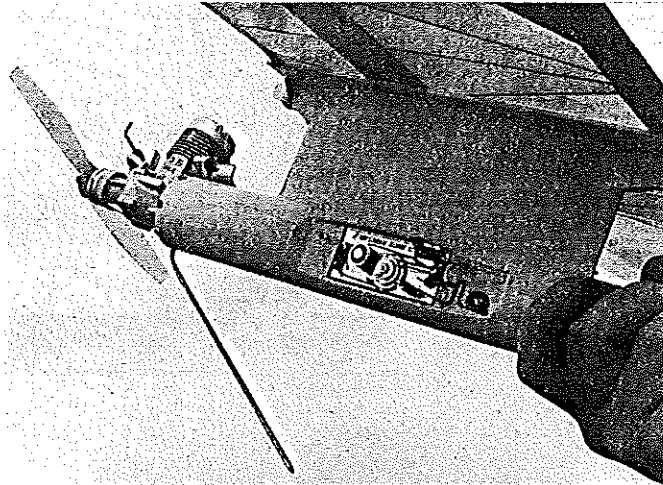

Seelig multifunction timer controls engine shutdown, auto rudder and stab, and DT functions. Note stout skid.

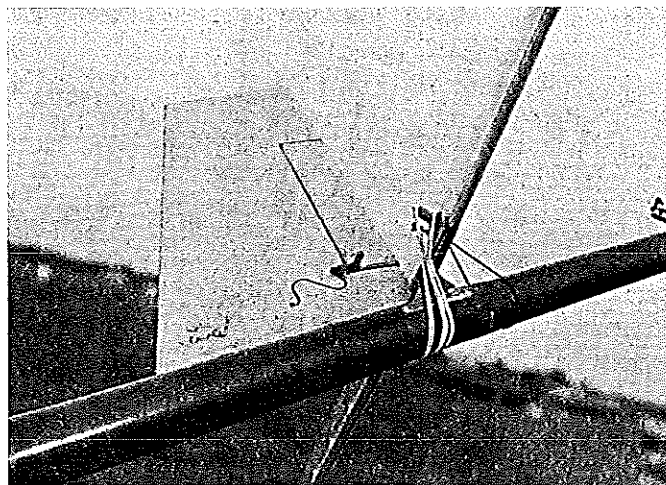

Rudder is sheet-covered structure with spring-loaded tab. Loop around fuselage attaches to stab, controls DT angle.

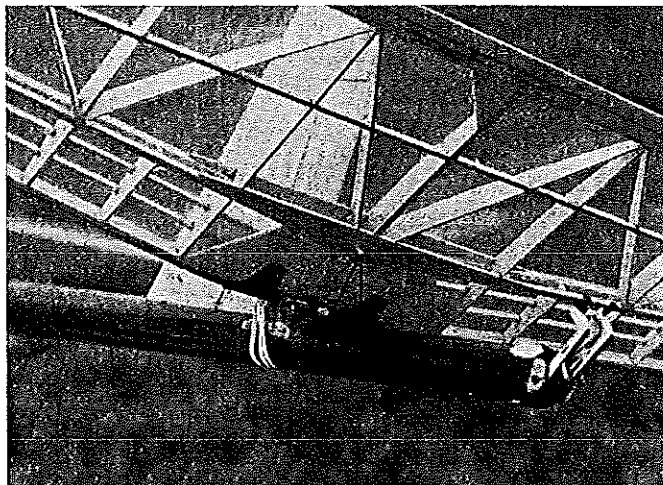

Hammers for stab glide and power positions pivot rearward for DT. Stab is covered with clear 1/2-mil Mylar.

was 49 grams heavier but produced a very stable configuration.

The wing and stabilizer utilize 9% and 6% simplex flat-bottom airfoils respectively. These airfoils are based on the logarithmic spiral that has the property of producing a curve that is geometrically similar to the original when cut to any length. This property is invaluable when building a wing with tapered planform. It allows all ribs to be cut from a master rib or curve.

This combination of airfoils, along with a 25% stabilizer set at a 34-inch moment, produces a very stable power pattern. The lightly loaded wing produces an impressively slow glide. Let's get on with its construction.

CONSTRUCTION

Anyone attempting to build this model should be familiar with basic construction; only unusual techniques or procedures will be provided.

Wing: At first glance the wing construction appears to be an overwhelming task; therefore it will be covered in some detail. The wing is built in five parts, which eliminates the typical center joint and associated stress concentration. All major bending and torsional loads are carried by the closed, fully tapered box spar. This spar is not built as a single unit; instead, it is assembled as an integral part of the wing construction. This construction technique allows the straight and diagonal ribs to carry through the spar.

The five-panel layout produces four dihedral joints, where wood sizes and densities can be tailored to minimize weight while still carrying loads.

Note and follow the wood sizes indicated on the plans. Center, main, and tip spar wood should be 8-10, 6-8, and 4-6 lb./cubic ft. respectively. The rest of the wing, which carries little load, is required only to define the airfoil shape; therefore, all other wing components should be from 4-6 lb. wood.

Niblite 584

Type: FF Class B

Wingspan: 71 1/2 inches (flat)

Wing area: 584 square inches

Engine: O.S. Max .25

Flying weight: 26.5 ounces

Construction: Built-up

Covering/finish: MonoKote and Mylar

The wing is built on a straight board big enough to mount all of the panels. The board is lightly sprayed with 3M 77 contact adhesive and the plans are stuck to the board. (If you are not familiar with this technique, practice the sticking and removal procedure with scraps.) The plans are sprayed with 3M 77 and covered with waxed paper; then the waxed paper is sprayed with 3M 77. This last layer holds the wing pieces in place while assembly occurs. This method allows fast construction without the use of any pins.

Construction begins by sticking the spar bottom, leading edge, and trailing edge bottom to the plans. Assure tight-fitting dihedral joints but do not glue at this time. Cut and glue the center section straight ribs in place.

The simplex airfoil is easily tailored for the tapered portion of the wing. Use the main wing rib pattern to cut six ribs for the center section. Each rib in the tapered portion of the wing is cut to fit. Shorter ribs use the full main rib, without spar notches, as a pattern. They are easily shortened and thinned.

A full-size rib is placed on the plan with its leading edge in place. The trailing edge length is then cut to size. A straightedge is placed along the bottom surface, aligned with the bottom leading edge and the trailing edge tip, and the rib is sliced along this line to form the new rib bottom. The rib is then placed on the plan and the location of the main spar and trailing edge are marked and cut. This produces a rib similar in shape yet shorter in length and thickness than the main rib. This procedure is repeated for every rib in the tapered portion of the wing. Once you are comfortable with this trim-to-fit method, a full set of ribs can be quickly completed. Remember to cut them in pairs—one for each wing half!

All straight main panel ribs, except for those at dihedral joints, are now glued in place using thick cyanoacrylate (CyA) glue. While the panels are stuck to the plan, use a long sanding block and even out any minor imperfections in the rib shapes. The panels are then removed from the plans and are joined to each other at the proper dihedral angles. A hair dryer will soften the 3M 77 if the panels are stuck to the waxed paper.

These partially built panels are very flexible, and when joined make a very spongy structure. Do not panic—remember that only one side of the box spar is in place at this time.

CyA the straight dihedral ribs in place. Lay the structure flat on a board. Starting with the center section cut, fit, and glue diagonal ribs in place. Use the rib-cutting procedure outlined previously, but use the length along the diagonals and the thickness at the centerline of the main spar for a guide. Tight joints at the main spar intersection add considerable strength to the structure.

The diagonal ribs will be slightly taller than the main ribs at their mid-span, due to the geometry involved. A few strokes with the sanding block will yield a smooth, consistent, fully tapered airfoil contour.

CyA the spar tops and trailing edge tops in place. Using the plans as a guide, notch the ribs and install stringer spars. The wing is now lifted from the board and repositioned









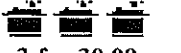

Wheels & Wings, etc.

1-800-896-2582

Orders Only Please !!

We Won't Be Undersold! Std Shipping only \$4.95!!

<h3 style="text-align: center;">Futaba</h3> <div style="text-align: center;">  <p>Futaba 6VA Only \$192.99</p> </div> <div style="text-align: center;">  <p>Futaba 4NBF Only \$138.99</p> </div> <div style="text-align: center;">  <p>S-148 SPECIAL 3 for 39.99 12.99 ea add'l</p> </div> <p>Futaba Servos</p> <table border="0" style="width: 100%;"> <tr><td>\$148 Bulk</td><td>14.99</td></tr> <tr><td>\$148w/Hdwe</td><td>16.99</td></tr> <tr><td>\$3001/metal</td><td>25.99</td></tr> <tr><td>\$3101 micro</td><td>34.99</td></tr> <tr><td>\$3002mini</td><td>52.99</td></tr> <tr><td>\$3302 1/4</td><td>53.99</td></tr> <tr><td>\$5101BB</td><td>34.99</td></tr> <tr><td>\$5102 Micro BB</td><td>49.99</td></tr> <tr><td>\$9303 BB HT</td><td>67.99</td></tr> <tr><td>\$9202 BB SHT</td><td>52.99</td></tr> <tr><td>\$9403 BB SHS</td><td>52.99</td></tr> </table> <p>Futaba Accessories</p> <table border="0" style="width: 100%;"> <tr><td>I27 DF 7 Ch Rec</td><td>77.99</td></tr> <tr><td>FM Crystals</td><td>Call</td></tr> <tr><td>FM Dual Conv</td><td>25.99</td></tr> <tr><td>Aileron Ext</td><td>5.99</td></tr> <tr><td>AEC13 Y Harness</td><td>9.99</td></tr> <tr><td>Tx batt for 6NFK</td><td>37.99</td></tr> <tr><td>NT-4 Rx bat</td><td>16.99</td></tr> <tr><td>Trainer Cord</td><td>13.99</td></tr> </table> <p>Hitec/RCD Servos</p> <table border="0" style="width: 100%;"> <tr><td>0300S Sid</td><td>11.99</td></tr> <tr><td>0422 Pro</td><td>16.99</td></tr> <tr><td>0605 Ultra</td><td>35.99</td></tr> <tr><td>0705 Giants</td><td>42.99</td></tr> </table> <p>Specify Air, Fut, or Jr</p>	\$148 Bulk	14.99	\$148w/Hdwe	16.99	\$3001/metal	25.99	\$3101 micro	34.99	\$3002mini	52.99	\$3302 1/4	53.99	\$5101BB	34.99	\$5102 Micro BB	49.99	\$9303 BB HT	67.99	\$9202 BB SHT	52.99	\$9403 BB SHS	52.99	I27 DF 7 Ch Rec	77.99	FM Crystals	Call	FM Dual Conv	25.99	Aileron Ext	5.99	AEC13 Y Harness	9.99	Tx batt for 6NFK	37.99	NT-4 Rx bat	16.99	Trainer Cord	13.99	0300S Sid	11.99	0422 Pro	16.99	0605 Ultra	35.99	0705 Giants	42.99	<h3 style="text-align: center;">JR PROPO</h3> <div style="text-align: center;">  <p>JR-XF 622 Free Shipping Only \$269.99</p> </div> <div style="text-align: center;"> <p>JR X-347 from \$399</p> <p>JR X-388S from \$489</p> <p>JR PCM10SX from \$989</p> </div> <p style="text-align: center;">Our policy is to Meet or beat any advertised Price</p> <p>Goldberg Glues Jet, Super, Slow 2 oz \$6.49 Buy 3 or More & Save \$.50 ea</p> <div style="text-align: center;">  <p>3 for \$17.97</p> </div> <p style="text-align: center;">Try our new CA's From NHP In Thin, Med & Thick</p> <table border="0" style="width: 100%;"> <tr><td>1 oz</td><td>2.89</td></tr> <tr><td>2 oz</td><td>4.99</td></tr> </table> <p style="text-align: center;">Guaranteed freshest</p> <p style="text-align: center;">If you don't see it, Ask!!</p> <p style="text-align: center;">Epoxies</p> <table border="0" style="width: 100%;"> <tr><td>6 Min 9 oz</td><td>7.49</td></tr> <tr><td>12Min 9 oz</td><td>7.49</td></tr> <tr><td>30Min 9 oz</td><td>7.49</td></tr> <tr><td>3HR 9 Oz</td><td>7.49</td></tr> </table>	1 oz	2.89	2 oz	4.99	6 Min 9 oz	7.49	12Min 9 oz	7.49	30Min 9 oz	7.49	3HR 9 Oz	7.49	<h3 style="text-align: center;">THUNDER TIGER</h3> <table border="0" style="width: 100%;"> <tr><td>Champion 45L</td><td>136.99</td></tr> <tr><td>World Trmr</td><td>99.99</td></tr> <tr><td>Windstar</td><td>76.99</td></tr> <tr><td>Decathalon</td><td>166.99</td></tr> <tr><td>Tiger Trainer</td><td>99.99</td></tr> <tr><td>Gull 1800</td><td>119.99</td></tr> </table> <p style="text-align: center;">MIDWEST PRODUCTS CO., INC.</p> <table border="0" style="width: 100%;"> <tr><td>Super Hots</td><td>89.99</td></tr> <tr><td>Malibu</td><td>61.99</td></tr> <tr><td>Aero-Star 40</td><td>66.99</td></tr> <tr><td>Aero-Star 60</td><td>116.99</td></tr> <tr><td>Mustang/Messerschmidt and Zero</td><td>73.99</td></tr> <tr><td>Sukhoi</td><td>82.99</td></tr> <tr><td>Mustang 60</td><td>115.99</td></tr> <tr><td>Corsair 40</td><td>85.99</td></tr> <tr><td>Cherokee 40</td><td>96.99</td></tr> <tr><td>AT6/Extra300</td><td>234.99</td></tr> </table> <p style="text-align: center;">CARL GOLDBERG</p> <table border="0" style="width: 100%;"> <tr><td>Electra Dlx</td><td>51.99</td></tr> <tr><td>Mirage 550</td><td>59.99</td></tr> <tr><td>Falcon III</td><td>61.99</td></tr> <tr><td>Super Chipmunk</td><td>108.99</td></tr> <tr><td>Ultimate Biipe</td><td>123.99</td></tr> <tr><td>Extra 300</td><td>117.99</td></tr> <tr><td>Eagle2</td><td>54.99</td></tr> <tr><td>Sophist'd Lady</td><td>34.99</td></tr> <tr><td>Gentle Lady</td><td>28.99</td></tr> <tr><td>Anniver Cub</td><td>66.99</td></tr> <tr><td>Tiger 2 (40)</td><td>61.99</td></tr> <tr><td>Tiger 2 (60)</td><td>88.99</td></tr> <tr><td>Sukhoi</td><td>143.99</td></tr> <tr><td>Float Kit</td><td>37.99</td></tr> </table> <p style="text-align: center;">Ultracote</p> <table border="0" style="width: 100%;"> <tr><td>Ultracote</td><td>9.99</td></tr> <tr><td>UltracoteF/lsent</td><td>12.99</td></tr> <tr><td>Ultracote Plus</td><td>11.99</td></tr> <tr><td>Ultracote Pls Fir</td><td>13.99</td></tr> </table> <p style="text-align: center;">3 Roll Special</p> <div style="text-align: center;">  <p>Save \$1.00/Roll 3 for \$26.97</p> </div> <p style="text-align: center;">MONOKOTE Lowest Possible Prices</p> <p style="text-align: center;">The Entire Line</p> <div style="text-align: center;">  <p>20% Off Retail</p> </div>	Champion 45L	136.99	World Trmr	99.99	Windstar	76.99	Decathalon	166.99	Tiger Trainer	99.99	Gull 1800	119.99	Super Hots	89.99	Malibu	61.99	Aero-Star 40	66.99	Aero-Star 60	116.99	Mustang/Messerschmidt and Zero	73.99	Sukhoi	82.99	Mustang 60	115.99	Corsair 40	85.99	Cherokee 40	96.99	AT6/Extra300	234.99	Electra Dlx	51.99	Mirage 550	59.99	Falcon III	61.99	Super Chipmunk	108.99	Ultimate Biipe	123.99	Extra 300	117.99	Eagle2	54.99	Sophist'd Lady	34.99	Gentle Lady	28.99	Anniver Cub	66.99	Tiger 2 (40)	61.99	Tiger 2 (60)	88.99	Sukhoi	143.99	Float Kit	37.99	Ultracote	9.99	UltracoteF/lsent	12.99	Ultracote Plus	11.99	Ultracote Pls Fir	13.99	<h3 style="text-align: center;">Engines</h3> <h4 style="text-align: center;">THUNDER TIGER</h4> <table border="0" style="width: 100%;"> <tr><td>GP 10 ABC</td><td>46.94</td></tr> <tr><td>GP 15 ABC</td><td>49.94</td></tr> <tr><td>GP 25 ABC</td><td>56.94</td></tr> <tr><td>GP 40 ABC</td><td>59.94</td></tr> <tr><td>GP61 ABC</td><td>94.94</td></tr> <tr><td>PRO25 ABC</td><td>84.94</td></tr> <tr><td>PRO36 ABC</td><td>89.94</td></tr> <tr><td>PRO40 ABC</td><td>94.94</td></tr> <tr><td>PRO46 ABC</td><td>99.94</td></tr> <tr><td>PRO61 ABC</td><td>148.94</td></tr> </table> <h3 style="text-align: center;">SAITO</h3> <table border="0" style="width: 100%;"> <tr><td>FA-50</td><td>214.94</td></tr> <tr><td>FA-65</td><td>244.94</td></tr> <tr><td>FA-91S</td><td>226.94</td></tr> <tr><td>FA-120-S</td><td>379.94</td></tr> <tr><td>FA-150</td><td>379.94</td></tr> </table> <p style="text-align: center;">Monthly Special Saito 150-GK</p> <div style="text-align: center;">  <p>Retail Only \$634.95 Add \$13 to upgrade any Saito to Golden Knight 409.99</p> </div> <p style="text-align: center;">O.S.</p> <table border="0" style="width: 100%;"> <tr><td>OS 25 FP</td><td>72.94</td></tr> <tr><td>OS 40 FP</td><td>74.94</td></tr> <tr><td>OS 60 FP</td><td>119.94</td></tr> <tr><td>OS 40 SF</td><td>137.94</td></tr> <tr><td>OS 46 SF</td><td>157.94</td></tr> <tr><td>OS 61SF</td><td>217.94</td></tr> </table> <p style="text-align: center;">Note All Saito Thunder Tiger and OS Ship Free</p> <div style="text-align: center;"> <p>Futaba YS 120 \$379.99</p> <p>Fox</p> <table border="0" style="width: 100%;"> <tr><td>40 BB STD</td><td>74.99</td></tr> <tr><td>40 BB DLX</td><td>79.99</td></tr> <tr><td>45BB R/CRng</td><td>84.99</td></tr> <tr><td>46 BB ABC</td><td>94.99</td></tr> <tr><td>50 BBR/C</td><td>92.99</td></tr> </table> <p style="text-align: center;">K&B</p> <table border="0" style="width: 100%;"> <tr><td>45 Sportster</td><td>56.99</td></tr> <tr><td>65 Sportster</td><td>65.99</td></tr> <tr><td>40 w/mfl</td><td>67.99</td></tr> <tr><td>61 R/C w/m</td><td>84.99</td></tr> </table> </div>	GP 10 ABC	46.94	GP 15 ABC	49.94	GP 25 ABC	56.94	GP 40 ABC	59.94	GP61 ABC	94.94	PRO25 ABC	84.94	PRO36 ABC	89.94	PRO40 ABC	94.94	PRO46 ABC	99.94	PRO61 ABC	148.94	FA-50	214.94	FA-65	244.94	FA-91S	226.94	FA-120-S	379.94	FA-150	379.94	OS 25 FP	72.94	OS 40 FP	74.94	OS 60 FP	119.94	OS 40 SF	137.94	OS 46 SF	157.94	OS 61SF	217.94	40 BB STD	74.99	40 BB DLX	79.99	45BB R/CRng	84.99	46 BB ABC	94.99	50 BBR/C	92.99	45 Sportster	56.99	65 Sportster	65.99	40 w/mfl	67.99	61 R/C w/m	84.99
\$148 Bulk	14.99																																																																																																																																																																																												
\$148w/Hdwe	16.99																																																																																																																																																																																												
\$3001/metal	25.99																																																																																																																																																																																												
\$3101 micro	34.99																																																																																																																																																																																												
\$3002mini	52.99																																																																																																																																																																																												
\$3302 1/4	53.99																																																																																																																																																																																												
\$5101BB	34.99																																																																																																																																																																																												
\$5102 Micro BB	49.99																																																																																																																																																																																												
\$9303 BB HT	67.99																																																																																																																																																																																												
\$9202 BB SHT	52.99																																																																																																																																																																																												
\$9403 BB SHS	52.99																																																																																																																																																																																												
I27 DF 7 Ch Rec	77.99																																																																																																																																																																																												
FM Crystals	Call																																																																																																																																																																																												
FM Dual Conv	25.99																																																																																																																																																																																												
Aileron Ext	5.99																																																																																																																																																																																												
AEC13 Y Harness	9.99																																																																																																																																																																																												
Tx batt for 6NFK	37.99																																																																																																																																																																																												
NT-4 Rx bat	16.99																																																																																																																																																																																												
Trainer Cord	13.99																																																																																																																																																																																												
0300S Sid	11.99																																																																																																																																																																																												
0422 Pro	16.99																																																																																																																																																																																												
0605 Ultra	35.99																																																																																																																																																																																												
0705 Giants	42.99																																																																																																																																																																																												
1 oz	2.89																																																																																																																																																																																												
2 oz	4.99																																																																																																																																																																																												
6 Min 9 oz	7.49																																																																																																																																																																																												
12Min 9 oz	7.49																																																																																																																																																																																												
30Min 9 oz	7.49																																																																																																																																																																																												
3HR 9 Oz	7.49																																																																																																																																																																																												
Champion 45L	136.99																																																																																																																																																																																												
World Trmr	99.99																																																																																																																																																																																												
Windstar	76.99																																																																																																																																																																																												
Decathalon	166.99																																																																																																																																																																																												
Tiger Trainer	99.99																																																																																																																																																																																												
Gull 1800	119.99																																																																																																																																																																																												
Super Hots	89.99																																																																																																																																																																																												
Malibu	61.99																																																																																																																																																																																												
Aero-Star 40	66.99																																																																																																																																																																																												
Aero-Star 60	116.99																																																																																																																																																																																												
Mustang/Messerschmidt and Zero	73.99																																																																																																																																																																																												
Sukhoi	82.99																																																																																																																																																																																												
Mustang 60	115.99																																																																																																																																																																																												
Corsair 40	85.99																																																																																																																																																																																												
Cherokee 40	96.99																																																																																																																																																																																												
AT6/Extra300	234.99																																																																																																																																																																																												
Electra Dlx	51.99																																																																																																																																																																																												
Mirage 550	59.99																																																																																																																																																																																												
Falcon III	61.99																																																																																																																																																																																												
Super Chipmunk	108.99																																																																																																																																																																																												
Ultimate Biipe	123.99																																																																																																																																																																																												
Extra 300	117.99																																																																																																																																																																																												
Eagle2	54.99																																																																																																																																																																																												
Sophist'd Lady	34.99																																																																																																																																																																																												
Gentle Lady	28.99																																																																																																																																																																																												
Anniver Cub	66.99																																																																																																																																																																																												
Tiger 2 (40)	61.99																																																																																																																																																																																												
Tiger 2 (60)	88.99																																																																																																																																																																																												
Sukhoi	143.99																																																																																																																																																																																												
Float Kit	37.99																																																																																																																																																																																												
Ultracote	9.99																																																																																																																																																																																												
UltracoteF/lsent	12.99																																																																																																																																																																																												
Ultracote Plus	11.99																																																																																																																																																																																												
Ultracote Pls Fir	13.99																																																																																																																																																																																												
GP 10 ABC	46.94																																																																																																																																																																																												
GP 15 ABC	49.94																																																																																																																																																																																												
GP 25 ABC	56.94																																																																																																																																																																																												
GP 40 ABC	59.94																																																																																																																																																																																												
GP61 ABC	94.94																																																																																																																																																																																												
PRO25 ABC	84.94																																																																																																																																																																																												
PRO36 ABC	89.94																																																																																																																																																																																												
PRO40 ABC	94.94																																																																																																																																																																																												
PRO46 ABC	99.94																																																																																																																																																																																												
PRO61 ABC	148.94																																																																																																																																																																																												
FA-50	214.94																																																																																																																																																																																												
FA-65	244.94																																																																																																																																																																																												
FA-91S	226.94																																																																																																																																																																																												
FA-120-S	379.94																																																																																																																																																																																												
FA-150	379.94																																																																																																																																																																																												
OS 25 FP	72.94																																																																																																																																																																																												
OS 40 FP	74.94																																																																																																																																																																																												
OS 60 FP	119.94																																																																																																																																																																																												
OS 40 SF	137.94																																																																																																																																																																																												
OS 46 SF	157.94																																																																																																																																																																																												
OS 61SF	217.94																																																																																																																																																																																												
40 BB STD	74.99																																																																																																																																																																																												
40 BB DLX	79.99																																																																																																																																																																																												
45BB R/CRng	84.99																																																																																																																																																																																												
46 BB ABC	94.99																																																																																																																																																																																												
50 BBR/C	92.99																																																																																																																																																																																												
45 Sportster	56.99																																																																																																																																																																																												
65 Sportster	65.99																																																																																																																																																																																												
40 w/mfl	67.99																																																																																																																																																																																												
61 R/C w/m	84.99																																																																																																																																																																																												

Add \$4.95 S/H & Ins up to 8#. O/S pkgs min \$7.95 2nd day & Next Day available. COD orders available only in continental USA only and add \$5.95 COD fee. Prices are cash prices (CC surchg 1.9%). Money Orders ship without delay. Allow 14 days for personal checks to clear. Due to advertising deadlines, & circumstances beyond our control, availability, specs & prices are subject to change. All merchandise carries manufacturers warranty only. Returns subject to restocking fee.

Wheels & Wings etc.

7620 Lyndale Ave S, Minneapolis, MN 55423

1-800-896-2582

Orders Only Please !!

For Information and other inquiries call:

1-612-861-6261

Name: _____

Address: _____

City: _____ St: _____

Zip Code: _____ Phone: _____

Item	Description	Price

CC _____ MO/Check _____ Subtotal: _____

Credit Card#: _____ Sales Tax: _____

Signature: _____ Exp _____ Shipping _____

TOTAL: \$ _____

Order Form

Since elephants don't fly very well -
try Peanuts!



Peck-Polymers Peanuts

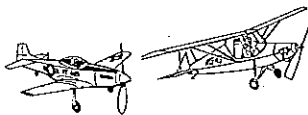

Stick & tissue models
under 13 inches in wingspan. © Peck-Polymers
Big rubber-powered fun in a small package.

Old Timer and Sport Models also available.

Ask for them at your local model shop or send \$4.00 for a full catalog. © Peck-Polymers



Peck-Polymers

P.O. Box 710399-MA Phone (619) 448-1818
Santee CA 92072 FAX (619) 448-1833

FIBER TAPE • TRIMSEAL • SKYLOFT • D/APPLICATOR

SIX SHOOTER FUEL PUMPS • POURING

NOW THAT YOU KNOW HOW TO FLY, IT'S TIME TO LOSE THE TRAINING WHEELS.

*Installing a set
of Southern Pro
Retracts in your
model improves its'
looks and flying
characteristics!*

EASY TO INSTALL
Compact size and simple
mounting makes the
installation a snap -
even when installing
our tri-gear retracts.

BUILT TO LAST
Ruggedly designed and
built to withstand the
high vibration and rough
use of today's high
powered aircraft.

POSITIVE LOCKS
Each retract securely
locks in both the up and
down positions.

LOW FRICTION
All moving parts are
supported by self-

centering nylon bearings.
All wear points are hard
anodized which will give
you years of use.

ONE SERVO ACTUATION
Our main or tri-gear
retracts can easily be
activated from a single
servo.

SEE YOUR DEALER
For more information,
see your dealer or give
us a call.

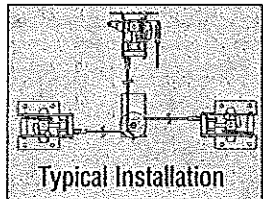

**AS LONG AS YOUR RADIO
WORKS, SOUTHERN PRO
RETRACTS WORK.
IF YOUR RADIO DOESN'T,
IT DOESN'T MATTER!**

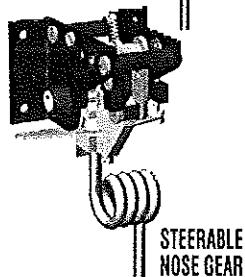
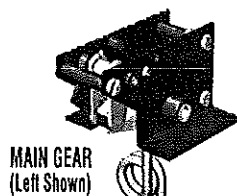

TRIG-3003 Tri-Gear
MAIN-3002 Main-Gear
NOSE-3001 Nose Gear

REPLACEMENT PARTS AVAILABLE

DAVE BROWN PRODUCTS INC.

4560 LAYHIGH ROAD, HAMILTON, OHIO 45013 • INFO: 513/738-1576 • FAX: 513/738-0152

with another panel flat. Complete the remaining panels in the same manner.

By now your wing should have taken on a structurally sound characteristic. Hold the wing in your lap and install the main spar vertical webs, trailing edge cap, and dihedral gussets. This step finally closes the box spar. Carve the leading edge shape, final-sand the top and bottom of the wing, and prepare to cover.

Transparent MonoKote is the preferred covering. Use care to evenly apply and shrink the MonoKote without introducing any unwanted warps. During the covering procedure wash-in the right main panel $\frac{3}{32}$ inch and wash-out each tip $\frac{1}{8}$ inch. Your completed wing should weigh about 237 grams and should be very strong.

Tail Surfaces: The stabilizer is built over the plans using the 3M 77 hold-down method described for the wing. There is very little load on the stabilizer, so only 4-6 lb. wood should be used. All ribs are made using the cut-to-fit method outlined for the wing.

The stab framework is given one coat of Balsarite and covered with $\frac{1}{2}$ -mil clear Mylar. The leading and trailing edges are sealed with a $\frac{3}{16}$ strip of clear MonoKote (Balsarite is not fuelproof).

The built-up rudder frame is covered with $\frac{1}{32}$ light balsa. The peg that extends into the fuselage is a $\frac{3}{16}$ hardwood dowel and provides considerable strength for the rudder-fuselage joint. Rudder tab movement is provided by Sig Easy Hinges that are thin-CyAed in place. A torsional rudder spring provides movement into the glide position. Rudder position stops are provided by 2-56 socket-head bolts. The rudder tab position must be very positive for consistent power adjustments. The rudder and tab are covered with transparent MonoKote.

Fuselage: The fuselage is built around a commercially available carbon tube that is manufactured for modeling use. It is simply cut to length, then used as the main fuselage structure.

(Several tube sources are listed at the end of the article; Ken Oliver's new aluminum/carbon/aluminum system appears to enjoy much popularity at this time. Ken also produces an insert doubler that is used to reinforce and mount the timer.)

The pylon is butt-glued to the tube with 3M DP-460 epoxy. The pylon-fuselage joint is then filleted with a 5-minute epoxy/microballoon mixture.

The engine is mounted using the backplate bolt holes. The mount and sleeve insert are custom-turned and provide a very light system.

The mounting ring that is inserted into the carbon tube has many $\frac{1}{8}$ lightening holes. These holes serve to form glue buttons that lock the ring to the carbon tube. If you do not have access to a lathe, Dub McCormick will turn parts to your specifications. The rudder, stab rest, and variable incidence tailplane (VIT) arms are secured with 3M DP-460 epoxy.

Rudder alignment is critical. Hold the fuselage securely in a vise or with clamps and use calipers to align the rudder leading edge

and trailing edge.

Stab tilt is provided by the position of the stab rest. Attach the wing to the completed fuselage and epoxy the stab rest in place with the proper tilt.

Begin finishing the front of the fuselage with three coats of Super Poxly filler, and sand thoroughly between each coat. Spray a final coat of filler, sanding lightly with 600-grit paper before spraying a final coat of color.

Use Super Poxly paint sparingly, as it can add weight quickly. A light coat of thinned clear Super Poxly will give your fuselage a brilliant shine.

Final Assembly: At this point your model is 95% complete, but the most important part of your building is yet to come.

Extreme care must be given to rigging and final assembly details. This care will make your model safe and consistent.

The brain of the model is the timer that controls the engine run, auto rudder, auto stab, and dethermalizer. Doug Galbreath provides a procedure for modification and care of all Seelig timers—*follow it exactly*. More free-flight models are demolished or lost by timer-related failures than by any other source.

The lines used for this model are .015 control line cable. Make sure your rigging lines are terminated such that they do not catch on the corners of the wire arms. Also assure that your DT wire does not become caught on the winding-scroll handle. This handle can be eliminated all together if a winding tool is used. Your floodoff system must be flawless—one failure, and your airplane is gone!

Make sure your stab power and glide positions are positive and that the lines apply enough tension to properly seat the stabilizer and rudder. Check the travel on the VIT arms to assure they move away from the stabilizer completely.

Set the DT angle as shown on the plans and make sure the lines do not tangle which could limit full travel. Set all timer functions and test both quick-DT and full-flight modes at least 20 times in your shop. Any failure mode must be resolved now.

Set the stabilizer position to 0° relative to the wing for the power setting. Set the glide position to two degrees relative to the wing. I belabor the details in this section, and you should also!

Once this setup has been completed you can journey to the flying field with the confidence that you will return with your model intact.

Flying: Begin your first flying session with a series of test glides with the stab and rudder in the glide positions. The objective is a floating glide with a gentle right-hand turn.

Continue test glides in the power position. The objective here is a shallow dive that is perfectly straight. If you are unfamiliar with this procedure, take a trimmed model and glide it in the power setting to get experience. Now set the timer for a two-second engine run and a quick-DT one second later. Run the engine on the ground until it runs consistently, testing the floodoff and quick-DT on the ground at least four times. Only after accomplishing this are you ready for the first flight.

Continued on page 50

FAIL SAFES

RAM has originated more "fail safes" than any other R/C manufacturer. Check out the latest versions at your local hobby shop or send a stamped, #10 envelope for full info.

RAM 09	BATTERY BACKER <i>redundant batt. syst. up to 60 size model</i>	\$39.95
RAM 11	LOW BATTERY ALARM <i>audio and visual, 4.8V or 9.6V</i>	24.95
RAM 12	LOW FUEL LIGHT <i>glo fuel monitor, visible in flight</i>	19.95
RAM 17	LOST PLANE FINDER <i>up to 80 DB at 10 ft. with ANY radio</i>	19.95
RAM 18	BIG AIRPLANE RF DE-GLITCHER SYSTEM <i>replaces 10 chokes</i>	8.95
RAM 22	SIMPLE CYCLER <i>discharges 4.8V & 9.6V batt. up to 600 MA</i>	19.95
RAM 25	BIG PLANE BATTERY BACKER <i>10 amp cap. w/2 switch harnesses</i>	59.95
RAM 26	BIG BATTERY CYCLER <i>discharges 4.8V batt. up to 4000 MA</i>	24.95
RAM 49	IGNITER 800 MA <i>on board driver/starter for 20 & 21 engine</i>	49.95
RAM 50	IGNITER 1300 MA <i>on board driver/starter for 35 & up engine</i>	49.95
RAM 62	SERVO FAIL SAFE <i>adj. safe point & delay, waterproofable</i>	24.95

If unavailable locally, send check, money order or full credit card info for the cost of the item plus \$4.00 (\$5.00 foreign) for immediate shipment. Include full address for U.P.S. Sorry no C.O.D.

RAM 229A E. Rollins Rd. — Round Lake Beach, IL 60073

BALL LINKS

DU-BRO
Has Always
Linked
Precision
With
Quality.

DU-BRO's reputation in the industry has been built on precision & quality. DU-BRO ball links are tolerance tested and precision made to insure smooth operation. With a wide variety of type and size, it's guaranteed you'll be able to find the missing link.

For a Free Catalog send \$1 for shipping & handling.

DU-BRO

DU-BRO Products • P.O. Box 815 • Wauconda, IL 60084

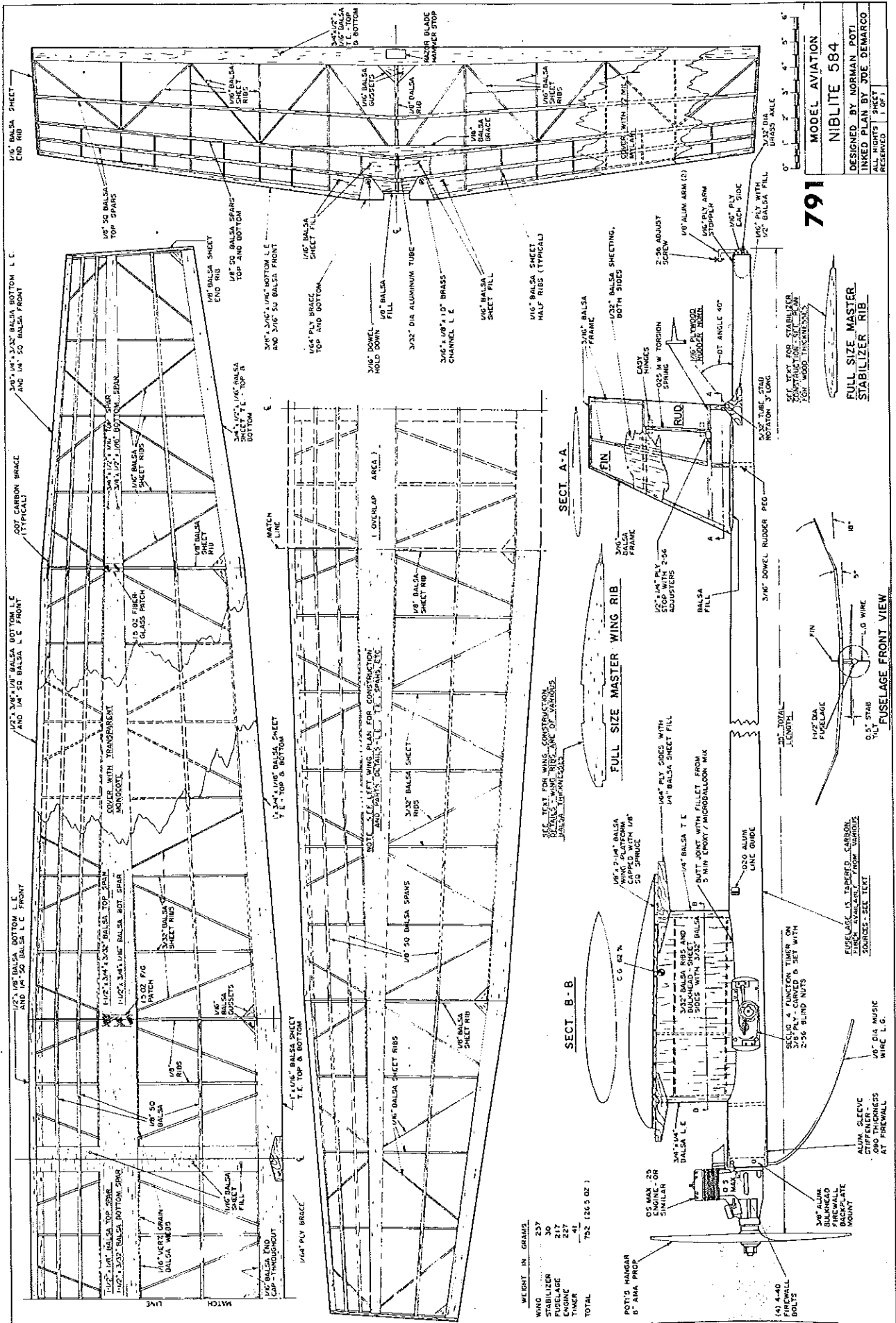

MODEL AVIATION
NIBLITE 584
 DESIGNED BY NORMAN POTI
 INKED PLAN BY JOE DEMARCO
 ALL RIGHTS RESERVED 1 OF 1

791

FULL SIZE MASTER
 STABILIZER RIB

WEIGHT IN GRAMS

WING	237
STABILIZER	30
FUSELAGE	227
TIMER	41
TOTAL	732 (265 OZ.)

POTI'S HANGAR
 6" AMA PROP
 OS MAX 25
 1/8" DIA MUSIC
 WIRE L.G.
 ALUM SLEEVE
 .005 THICKNESS
 AT FIREWALL
 (A) 4-40
 FIREWALL
 BOLTS
 3/8" ALUM
 BUSHHEAD
 BACKPLATE
 MOUNT



50th ANNIVERSARY EDITION

PITTS SPECIAL

50th ANNIVERSARY
1 9 4 5 - 1 9 9 5

FULLY ASSEMBLED!

SPECIFICATIONS
WINGSPAN: 10 in (254 mm)
LENGTH: 9.25 in (235 mm)
ENGINE: Pos Wed .020

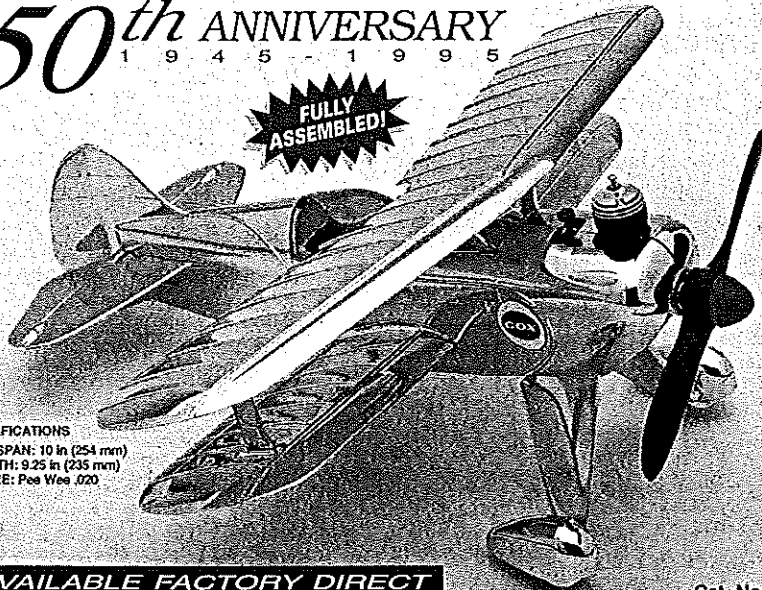

AVAILABLE FACTORY DIRECT
Credit Card Orders Call Toll Free 1-800-451-0339

Cat. No. 50 Pitts Special \$50.00 each plus \$4.00 S&H
For mail orders please send check or money order made payable to Cox Products. Please include your return address. CA residents include 7.75% sales tax.
Send to: Cox Products Dept. N2
475 N. Sheridan St., Corona, CA 91720-2004

Cat. No. 50

COLLECTOR SERIES

50th Anniversary Edition Pitts Special features include: authentic scale details, gold metalized high impact styrene, certificate of authenticity, individually numbered.

© 1995, COX PRODUCTS, INC.

RC FLIGHT SCHOOL

Learn to fly with our planes at a private field. Five (or 6) day course \$350. Open year round. Send SASE for complete info to: Southwest RC Flying, 2818 Carolina NE, Albuquerque NM 87110. 505-832-6394

FIBERGLASS CLOTH

Premium Grade
3/4 oz 38"W 10 yrd. min. \$2.50 yd.
Lower Prices 30 yds. & up
Other Weights Available



TinLin's

17 Andrews Drive • Daleville, AL 36922
(334) 598-2287 • 4:00 - 10:00 CST

Easily replaces leaky, old brass, fuel cap fittings!

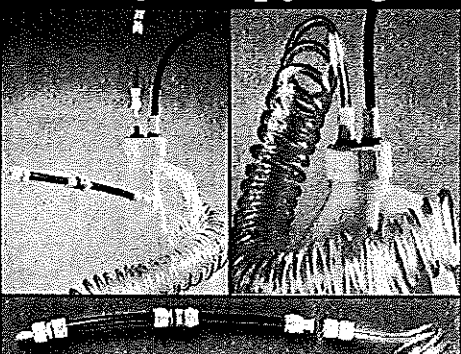

ADVANCED AERO FUELER

- Complete Fuel Cap System
- Makes Fueling Easier
- Airtight and Resealable
- Glow and Gasoline
- Actually Pays For Itself
- Safety Seal Open Fuel Containers
- All Fittings are Tough Nylon

Complete Kit 90% Assembled
5 working feet of coiled tubing, Fittings, & Fueler Probe

\$12.95

22nd Century Quick Lock Fittings

"I've looked for these fittings for years!"

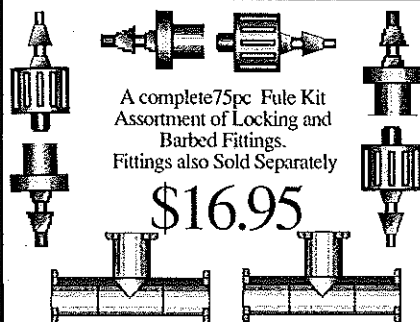

A complete 75pc Fuel Kit
Assortment of Locking and Barbed Fittings.
Fittings also Sold Separately

\$16.95

- Actual size shown
- Vibration Resistant
- Excellent For Fuel, Pressure & Smoke
- Locking and Barbed Fittings

24Hr. Order Hotline 805 943-7996
22nd Century Aero Products, Inc.

2763 West Ave L Suite 295
Lancaster, CA 93536

CA residents add 8.25% sales tax
Add \$3.00 Shipping and Handling Within USA

MASTERCARD & VISA ACCEPTED

Copyright 1995 Patent Pending

Niblite/Poti

Continued from page 45

Reset the timer and launch the model straight up for a two-second run and a quick DT. Gradually increase engine runs, trimming for a straight up climb with a slight roll to the right. This model jumps out of your hand and will impress even experienced free-flyers.

For the first gliding flight set the DT for only 20 seconds. This allows for a DT with plenty of altitude in case the glide position is grossly off or the glide function malfunctions. If this function check is satisfactory, "dial in" the glide with flights of longer duration. Your model is now competition-ready.

The 584 is powered by a stock O.S. Max .25 ducted fan engine. Using 60% nitro, the engine turns a Poti's Hangar 8 x 3 fiberglass propeller at 23,000 rpm. *Never use a plastic or wood prop on an engine of this potential. Your safety, and that of nearby spectators, is of utmost importance.*

This model draws attention every time it is flown, and both competitors and spectators enjoy its spectacular performance. All but final flyoff flights can be attained without thermal help.

Possible design improvements that you might consider are decreasing the wing thickness to 8%; lowering the stabilizer area to 20%; shortening and thinning out the pylon; and/or using a smaller-diameter carbon tube. A meticulous builder might also remove 30-40 grams of additional weight.

This design has been scaled up to a 750 square inch C-D Gas model that has successfully begun to earn its own reputation. It has also been scaled down to a 310-square-inch FIJ size. These three sizes provide the author with a configuration for almost any AMA Gas event.

It has been gratifying to see the interest and accolades this model has garnered. Please contact me with questions or comments about its construction or flying. You will be impressed, and I will be pleased, once your Niblite 584 is airborne! Thermals. →

Norman D. Poti
5695 Marshall Rd.
Dayton OH 45429

Source List

Carbon Tubes:

Ken Oliver
2213 El Cejo Circle
Rancho Cordova CA 92041

Bob Waterman
4480 Northwest Wallowa Ct.
Portland OR 97229

Custom Machining:

Dub McCormick
3800 Shellbrook Ave.
Fort Worth TX 76109

Sellig Timers:

Doug Galbreath
2810 Cowell Blvd.
Davis CA 95616